

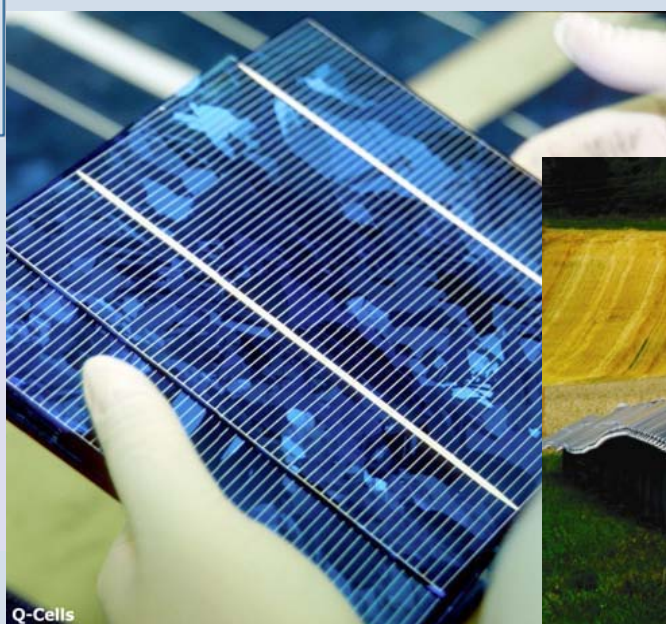

Methodological Guidelines on Net Energy Analysis of Photovoltaic Electricity



Q-Cells



Karlstadt Laudenbach, Germany (810 kW); Phoenix Solar

PVPS

PHOTOVOLTAIC
POWER SYSTEMS
PROGRAMME

Report IEA-PVPS T12-07:2016

INTERNATIONAL ENERGY AGENCY
PHOTOVOLTAIC POWER SYSTEMS PROGRAMME

Methodological Guidelines on Net Energy Analysis of Photovoltaic Electricity

IEA PVPS Task 12, Subtask 2.0 LCA
IEA-PVPS T12-07:2016
ISBN 978-3-906042-39-8

January 2016

Operating agents:

Garvin Heath, National Renewable Energy Laboratory, Golden, CO, USA
Carol Olson, Energy Research Center of the Netherlands, Petten, The Netherlands

Author:

Marco Raugei

Contributors:

Rolf Frischknecht, Carol Olson, Parikhit Sinha, Garvin Heath

Citation:

M. Raugei, R. Frischknecht, C. Olson, P. Sinha, G. Heath, 2016. Methodological guidelines on Net Energy Analysis of Photovoltaic Electricity, IEA-PVPS Task 12, Report T12-07:2016, ISBN 978-3-906042-39-8.

Summary

Net Energy Analysis (NEA) is a structured, comprehensive method of quantifying the extent to which a given energy source is able to provide a net energy gain (i.e., an energy surplus) to the end user, after accounting for all the energy losses occurring along the chain of processes that are required to exploit it (i.e., for its extraction, processing and transformation into a usable energy carrier, and delivery to the end user), as well as for all the additional energy ‘investments’ that are required in order to carry out the same chain of processes. However, this general framework leaves the individual practitioner with a range of choices that can affect the results and thus, the conclusions of a NEA study. The current IEA PVPS guidelines were developed to provide guidance on assuring consistency, balance, and quality to enhance the credibility and reliability of the results from photovoltaic (PV) NEAs. The guidelines represent a consensus among the authors - PV NEA experts in North America, Europe, and Asia - for assumptions made on PV performance, process inputs and outputs, methods of analysis, and reporting of the results.

Guidance is given on photovoltaic-specific parameters used as inputs in NEA and on choices and assumptions in inventory data analysis and on implementation of modelling approaches. A consistent approach towards system modelling, the functional unit, the system boundaries and allocation aspects enhances the credibility of PV electricity NEA studies and enables balanced NEA-based comparisons of different electricity producing technologies.

This document provides an in-depth discussion of a common metric of NEA, namely the energy return on investment (EROI), and how this is to be interpreted *vis-à-vis* the deceptively similar-sounding metrics in the field of Life Cycle Assessment (LCA): cumulative energy demand (CED) and non-renewable cumulative energy demand (nr-CED) per unit output. Specifically, a number of key differences are highlighted between these metrics as applied to electricity production systems, which are listed in **Table S-1**.

Transparency in reporting is of the utmost importance as parameters vary with geographical zones, and a system’s boundary conditions and modelling approach can affect the findings significantly. Reporting of items 1 to 16 below is considered mandatory. The list of items is separated into key parameters required in both the captions of figures and tables showing the results of the NEA and in the NEA report (items 1 to 6), and further important aspects which should be documented elsewhere in the NEA report. Key parameters that should be documented in captions of figures and tables:

1. PV technology (e.g., single and multi-crystalline silicon, cadmium telluride (CdTe), copper indium diselenide (CIS), amorphous silicon, micromorphous silicon);
2. Type of system (e.g., rooftop, ground mount, fixed tilt or tracker);
3. Module-rated efficiency and degradation rate (if not included in performance ratio);

4. Lifetime for both PV modules and balance of system (BOS);
5. Location of installation; and
6. Annual irradiation level, and expected annual electricity production with the given orientation and inclination *or* system's performance ratio (PR).

Other important aspects that should be documented in an NEA report:

7. Place/country/region of electricity production modelled;
8. Time-frame of data used in the analysis;
9. Whether $EROI_{el}$ (EROI in terms of electricity) or $EROI_{PE-eq}$ (EROI in terms of equivalent primary energy) is calculated, and if the latter, the assumed electricity mix or technology/-ies and thus resulting grid mix's or technology's/-ies' efficiency;
10. Goal of the study;
11. System boundary;
12. Approach used if not process-based (e.g., environmentally extended input-output tables, hybrid analysis);
13. LCA database(s) (e.g., Ecoinvent, GaBi, ELCD, etc.) and version used (if applicable);
14. LCA software tool (e.g., SimaPro, GaBi, OpenLCA, etc.) and version used (if applicable);
15. Primary energy factors applied and approach used; and
16. Any major assumptions made about the production of input materials.

Metric	EROI _{el}	EROI _{PE-eq}	CED	nr-CED
Formula	$\frac{Out_{el}}{Inv}$	$\frac{Out_{PE-eq}}{Inv} = \frac{(Out_{el}/\eta_G)}{Inv}$	$\frac{(PE+Inv)}{Out_{el}}$	$\frac{(PE_{nr}+Inv_{nr})}{Out_{el}}$
Units	[MJ / MJ]	[MJ / MJ]	[MJ / MJ]	[MJ / MJ]
Meaning of the numerator	Energy delivered ('returned') to society, <u>in units of electricity</u>	Energy delivered ('returned') to society, <u>in units of equivalent primary energy</u>	<u>Total primary energy</u> harvested from nature	<u>Non-renewable primary energy</u> harvested from nature
Meaning of the denominator	Sum of energy carriers diverted from other societal uses (excluding energy delivered to society), <u>in terms of their total primary energy demand</u>		Energy delivered ('returned') to society, <u>in units of electricity</u>	
Distinction between renewable and non-renewable energy?	No, not normally made		Yes, generally recommended	
Main purpose	Economical/effective use of available energy carriers		Efficient use of primary energy resources	Sustainable/efficient use of non-renewable primary energy resources
Temporal perspective	Short term		Long term	

Table S-1 - Key differences between EROI_{el} / EROI_{PE-eq} and CED / nr-CED per unit output. (Acronyms, abbreviations and symbols: PE = primary energy; PE-eq = equivalent primary energy; Out = energy output; Inv = energy investment; el = electricity; η_G = life cycle energy efficiency of the electric grid (G); nr = non-renewable.)

Foreword

The International Energy Agency (IEA), founded in November 1974, is an autonomous body within the framework of the Organization for Economic Cooperation and Development (OECD) that carries out a comprehensive programme of energy co-operation among its member countries. The European Commission also participates in the work of the IEA.

The IEA Photovoltaic Power Systems Programme (PVPS) is one of the collaborative Research and Development (R&D) agreements established within the IEA. Since 1993, participants in the programme have been conducting a variety of joint projects in the applications of photovoltaic (PV) conversion of solar energy into electricity.

The mission of the PVPS is “...to enhance the international collaboration efforts which accelerate the development and deployment of photovoltaic solar energy as a significant and sustainable renewable energy option”. The underlying assumption is that the market for PV systems gradually is expanding from the niche-markets of remote applications and consumer products to rapidly growing ones for building-integrated and centralised PV-generation systems.

A PVPS Executive Committee is composed of one representative from each participating country; Stefan Nowak of Switzerland heads the overall programme. Operating Agents assume responsibility for managing individual research projects (Tasks). By the end of 2007, twelve Tasks were established within the programme.

Task 12 engages in fostering international collaboration in communicating and assessing the environmental, health and safety (EH&S) aspects of PV technology over the life cycle of the PV systems. Task 12 also disseminates reliable and accurate information on the EH&S impacts of PV technology to policymakers, industry participants and the public with the goal to improve consumer understanding and confidence, encourage industry best practices, and aid policymakers to make informed decisions in the course of the energy transition. Furthermore, Task 12 brings its expertise in assessing methods and standards for the evaluation of EH&S aspects of PV systems. The overall objectives of Task 12 are to:

- Quantify the environmental profile of PV electricity using a life cycle approach in order to improve the sustainability of the supply chain and to compare it with the environmental profile of electricity produced with other energy technologies
- Aim for a closed-loop supply chain by and help improve PV waste management through collection and recycling, including legislative developments as well as development of technical standards
- Distinguish and address actual and perceived issues touching the EH&S aspects of PV technology that are important for market growth.

The first objective of this task is well served by life cycle assessments (LCAs) that describe the energy-, material- and emission-flows in all the stages of the life cycle of PV. The second objective will be addressed by assisting the collective action of PV companies in defining material availability and product-recycling issues.

Within Task 12, a Subtask on Life Cycle Assessment includes three targets: to quantify the environmental profile of electricity produced with PV systems (compared to that from other sources); to evaluate trends in the environmental profile of PV; and to assess this profile with the help of "external" costs and other life cycle impact assessment methods.

Net Energy Analysis (NEA) is viewed as an independent method for obtaining further valuable information on the energy performance of PV systems that is complementary to LCA because of it provides answers to a distinctly different question. Task 12 has produced and will continue to update methodological guidelines for PV LCA and now, with this document, it is doing the same for PV NEA. Further information on the activities and results of the Task can be found at www.iea-pvps.org.

Contents

List of acronyms and symbols	1
1. Motivation for the present document.....	2
2. Net Energy Analysis (NEA)	3
2.1. Brief historical outline	3
2.2. Energy Return on (Energy) Investment (EROI).....	3
3. Methodological guidelines.....	7
3.1 NEA of PV electricity production.....	7
3.2. Interpretation of EROI (<i>vis-á-vis</i> CED and nr-CED).....	11
3.3 Photovoltaics-specific aspects	14
3.4 Modelling aspects	15
3.4.1 ‘Integrated’ vs. ‘dynamic’ modelling.....	15
3.4.2 Goal definition	17
3.4.3 Functional unit	18
3.4.4 System boundary	18
3.4.5 Modelling allocation and recycling.....	21
3.5 Reporting and communication.....	22
Acknowledgements.....	22
References	23

List of acronyms and symbols

AC	=	Alternated Current
BOS	=	Balance Of System
CdTe	=	Cadmium Telluride
CIS	=	Copper Indium diSelenide
CED	=	Cumulative Energy Demand
DC	=	Direct Current
EC	=	Energy Carrier
EPBT	=	Energy Pay-Back Time
EROI	=	Energy Return On (Energy) Investment
Inv	=	Energy Investment
Inv _{nr}	=	non-renewable energy Investment
LCA	=	Life Cycle Assessment
LCI	=	Life Cycle Inventory
mc-Si	=	multi-crystalline Silicon
MJ	=	MegaJoules
NEA	=	Net Energy Analysis
nr-CED	=	non-renewable Cumulative Energy Demand
Out	=	Energy output
PE	=	Primary Energy
PE _{nr}	=	non-renewable Primary Energy
PES	=	Primary Energy Source
PR	=	Performance Ratio
PV	=	Photovoltaic

1. Motivation for the present document

The quantification of the energy performance of photovoltaic (PV) electricity is critical information for decision makers to make sound choices in the crowded arena of competing energy alternatives.

With the multitude of available energy performance metrics and methods, it is crucial to critically review them to see A) what information is conveyed by each metric, B) whether it adequately informs about the efficiency or effectiveness of the PV system, C) whether the metric is suitable for the purpose to which it is applied (e.g., comparison with other electricity generation technologies, or as a policy tool, from a short- or long-term perspective) and D) which, if any, are its lingering methodological issues.

This document critically assesses the discipline of Net Energy Analysis (NEA), and specifically aims to provide clear recommendations on how to perform a NEA of PV electricity, and interpret its principal energy performance metric - Energy Return On Investment (EROI) - *vis-à-vis* the deceptively similar-sounding metrics in the field of Life Cycle Assessment (LCA) - Cumulative Energy Demand (CED) and Non-renewable Cumulative Energy Demand (nr-CED).

Specifically, the EROI of PV systems has been the focus of much controversy [Raugei et al., 2012; Prieto and Hall, 2013; Weißbach et al., 2013; Raugei, 2013b; Raugei et al., 2015; Brandt et al., 2013; Pickard, 2014; Carbajales-Dale et al., 2015; Bhandari et al., 2015], especially with regards to how it compares to that of more conventional (e.g., thermal) electricity production pathways. If such comparisons are performed, the strict limitations of such comparisons should be highlighted as described in this document.

2. Net Energy Analysis (NEA)

2.1. Brief historical outline

The first proposals to complement the economic analysis of societal processes with information on material and energy flows (accounted for in physical units) date back to the late nineteenth century [Sacher, 1881; Geddes, 1884; Clausius, 1885]. An 'energy theory of value' was also advocated by the Technocracy movement in the United States of America beginning in the 1920s [Berndt, 1982], when, in the years up to and during the Great Depression, there was a call for replacing monetary currency (which is subject to value fluctuations) with an energy-based currency. The same fundamental idea then received further credit and general attention during the 1973-1974 oil crisis, when U.S. legislation, sponsored by Sen. Mark Hatfield, was incorporated into law requiring that all prospective energy supply technologies considered for commercial application be assessed and evaluated in terms of their "potential for production of net energy". Hatfield [1974] argued that "energy is the currency around which we should be basing our economic forecasts, not money supply".

As a scientific discipline, Net Energy Analysis (NEA) was thus developed to evaluate the extent to which a given energy resource flow is able to provide a net energy gain (i.e., an energy surplus) to the end user, after accounting for all the energy losses occurring along the chain of processes that are required to exploit it (i.e., for its extraction, processing and transformation into a usable energy carrier, and then delivery to the end user), as well as for all the additional energy 'investments' (i.e., those that do not directly form part of the original flow of energy resource that is being exploited) that are required in order to carry out the same chain of processes [Slessor 1974; Leach 1975; Chambers, 1979; Herendeen, 1988; Cleveland 1992; Herendeen, 2004; Arvesen and Hertwich, 2015].

It has been claimed that "net energy analysis ... is immune to the effects of market imperfections that distort monetary data" [Cleveland, 2013], with examples of such "market imperfections" being subsidies, government policies, etc. However, some NEAs have in fact included the use of economic factors translated into energy units (*cf.* **Section 3.4.4**), and in these cases, they may therefore no longer be claimed to be immune to market imperfections.

2.2. Energy Return on (Energy) Investment (EROI)

A principal indicator of NEA is the Energy Return On (Energy) Investment (EROI, sometimes alternatively spelled EROEI or ERoEI), which is defined as the ratio of the amount of energy delivered (also referred to as 'returned') to society in the form of a useful energy carrier (EC)¹ by a chain of processes exploiting a primary energy source (PES) to the total energy 'invested'

¹ "A primary energy source is an energy source that exists in nature and can be used to generate energy carriers (e.g., solar radiation, fossil fuels, or waterfalls). An energy carrier is a vector derived from a primary energy source (e.g., electricity, gasoline, or steam)" [Murphy and Hall, 2011].

in finding, extracting, processing, and delivering that energy [Cleveland et al., 1984; Murphy and Hall, 2010].

Referring to the generalized **Figure 1** below, we have:

- **PE** = primary energy directly harvested from the PES
- **Inv** = energy ‘investment’ for the chain of energy harvesting and transformation processes
- **Out** = energy ‘return’ (i.e., gross amount of usable energy carrier delivered to society)
- **S** = energy dissipated to the environment (e.g., as heat, as fugitive emissions, etc.)

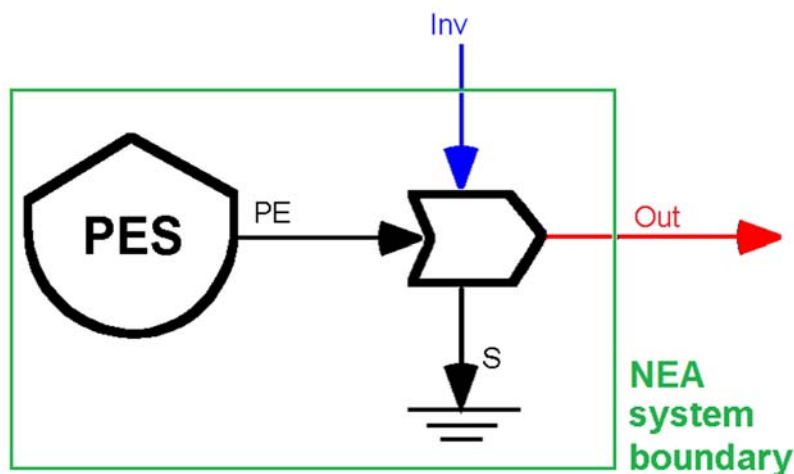

Figure 1 - Streamlined energy systems diagram of the exploitation of a primary energy source (PES) for the production of a useful energy carrier (**Out**), with concomitant primary energy directly harvested from the PES (**PE**), additional external energy investment (**Inv**) and energy dissipated to the environment (**S**). (This and all subsequent energy system diagrams in this document follow the symbolic conventions introduced by Odum [1983])

The Energy Return On Investment (EROI) is defined as:

$$\text{Eq. 1) } \text{EROI} = \text{Out} / \text{Inv}$$

The fundamental idea underpinning EROI is that, in order for an energy production system to provide a positive net energy ‘return’ to the end user ($\text{Out}_{\text{NET}} = \text{Out} - \text{Inv}$), the gross energy return (**Out**) must be larger than the available energy ‘invested’ in the chain of energy harvesting and transformation processes that make up the system itself (**Inv**).

It is straightforward to verify that $\text{Out}_{\text{NET}} > 0$ implies $\text{Out} > \text{Inv}$, and hence $\text{EROI} > 1$.

However, a number of caveats apply.

1. **PE** is in units of primary energy², and includes both the primary energy actually harvested and subsequently converted into the delivered energy carrier and the primary energy co-extracted but then ‘lost’ to the environment (which forms part of **S**).
2. **Inv** is the readily available energy *diverted from other possible societal uses*, and as such it is provided to the system as a combination of usable energy carriers. However, accounting for the range of different energy carriers contributing to the denominator (**Inv**) in terms of their individual amounts measured in direct units of, e.g., thermal energy for fuels and electrical energy for electricity, would lead to an inconsistent sum of non-directly comparable energy flows. To overcome this issue, we recommend expressing all contributions to the energy investment (**Inv**) in terms of their life cycle primary energy demand, calculated as the total primary energy harvested from the environment in order to produce and deliver them (i.e. on the basis of their Cumulative Energy Demand [Frischknecht et al., 2007; Frischknecht et al., 2015a]).
3. **Out** may *either* be accounted for in direct energy units of the delivered energy carrier (i.e., **Out_{th}** measured in units of thermal energy in the case of a fuel, or in **Out_{el}** measured in units of electrical energy in the case of electricity), *or*, like **Inv**, in terms of its *equivalent* primary energy (**Out_{PE-eq}** measured in units of primary energy). Adopting the latter protocol requires the adoption of a suitable conversion factor between one unit of delivered energy carrier and X units of primary energy. As discussed elsewhere [Murphy et al., 2011; Arvesen and Hertwich, 2015], a number of different approaches have been used in the NEA literature to perform this conversion, e.g. based on the concept of exergy, or on economic price. Many such approaches, however, lead to a lack of methodological consistency when the results of the NEA are discussed in the same light as those ensuing from LCA, and they are therefore hereby discouraged. Instead, the approach that is recommended here follows a replacement logic akin to that used in LCA, whereby one unit of energy carrier delivered by any one technology is assumed to be *equivalent* to the primary energy that is cumulatively harvested from the environment by the current mix of technologies deployed in a given country or region in order to produce the exact same unit of energy carrier (e.g., that country’s or region’s grid mix in the case of electricity)³. In other words, the conversion factor between one unit of delivered energy carrier (e.g., thermal or

² Common practice is to express all units of primary energy on a Higher Heating Value (HHV) basis, thereby including, when applicable, the latent heat of the water vapour generated during combustion [Frischknecht et al. 2007]. Such convention is assumed here throughout, unless otherwise specified.

³ In LCA, energy equivalency may alternatively be defined on the basis of the current mix of *non-renewable* technologies, such as e.g. a country’s *non-renewable* share of its grid mix. For example, such distinction leads to the alternative definition of, respectively, either Energy Pay-Back Time (EPBT), or Non-Renewable Energy Pay-Back Time (NREPBT) [Frischknecht et al., 2016]. However, given that NEA does not generally distinguish between renewable and non-renewable energy flows (*cf.* **Section 3.2**), the use of the total mix of renewable *and* non-renewable technologies is recommended for the purposes of calculating the *equivalent* primary energy at the numerator of the EROI ratio.

electrical energy) and its equivalent primary energy is taken to be the Cumulative Energy Demand of the mix of technologies that is being replaced.

From points (2) and (3) above, it follows that, unless the numerator (**Out**) and the denominator (**Inv**) of the EROI ratio are both expressed in terms of units of primary energy, their difference (**Out_{NET}**) is no longer strictly consistently defined, and the “intuitively appealing interpretation that $EROI > 1$ is the absolute minimum requirement a resource must meet in order to constitute a net energy source” is lost [Arvesen and Hertwich, 2015].

On the other hand, if the energy return *is* expressed in units of *equivalent* primary energy (**Out_{PE-eq}**), then the resulting EROI is no longer an *absolute* indicator of the energy performance of the analysed system, but it becomes a *relative* indicator of its performance *which may only be interpreted in the context of the technology mix that it is assumed to replace*.

In either case, according to its definition (**Eq. 1**), EROI is essentially a user-centric ratio of energy ‘benefits’ (the ‘return’) to energy ‘costs’ (the ‘investment’), which has been interpreted as having inherent implications for the economy [Murphy et al., 2011; Carbajales-Dale et al., 2014a]. It has also been argued that it may be regarded as an indicator of the ‘quality’ of an energy resource, where the word ‘quality’ is meant as “ability to generate economic output” [Murphy et al., 2011] (the reasoning being that a larger amount of net energy being made available to the economy allows more work to be carried out per unit of energy invested).

Additionally, by analysing a time series where a progressive change in EROI is observed for a specific energy resource, a useful indication may be derived of the comparative ease with which such energy resource has been exploited over time, and therefore of its changing overall net energy contribution to the economy. For instance, Hall et al. [2014] have reviewed calculations which indicate a declining trend for EROI values of petroleum oil over the past decades, which appears to indicate that, in general terms, more energy is required today to find, extract, process and deliver petroleum fuels from crude reserves that are less accessible, or of lower quality, than those that were being exploited, for instance, a half century ago. Hence, the declining EROI of oil products over time may indirectly indicate the encroaching physical scarcity of global petroleum resources.

If observed, similar EROI trends for other non-renewable primary energy sources may then also be potentially interpreted as indicative of similar trends [Murphy et al., 2011]. However, when calculated at the scale of an entire industrial sector, EROI becomes a flow-based metric (*cf.* **Sections 3.4.1** and **3.4.4**), and it is therefore subject to varying levels in investment from year to year, which only generate returns in subsequent years, thereby changing the EROI. Only a clear long-term trend above the year-to-year variability would thus lend itself to such a clear-cut interpretation [Brandt, 2011].

Finally, EROI has been presented as a family of possible calculations with a widening circle of system boundaries (*cf.* **Section 3.4.4**) [Mulder and Hagens, 2008; Murphy and Hall, 2010; Murphy et al., 2011]. To assess whether an energy technology may serve as a viable provider of net useful energy to a modern society, extended-boundary EROI analyses aim to account not only for direct and indirect energy use and investments, but also for indirect non-energy inputs. However, the methods and boundaries for capturing the latter are still disputed in the scientific literature; also, the overall minimum EROI required to support a modern society is the object of much speculation [Hall et al., 2009; Lambert et al., 2014].

3. Methodological guidelines

3.1 NEA of PV electricity production

Figure 2 below schematically illustrates a photovoltaic (PV) electricity production system.

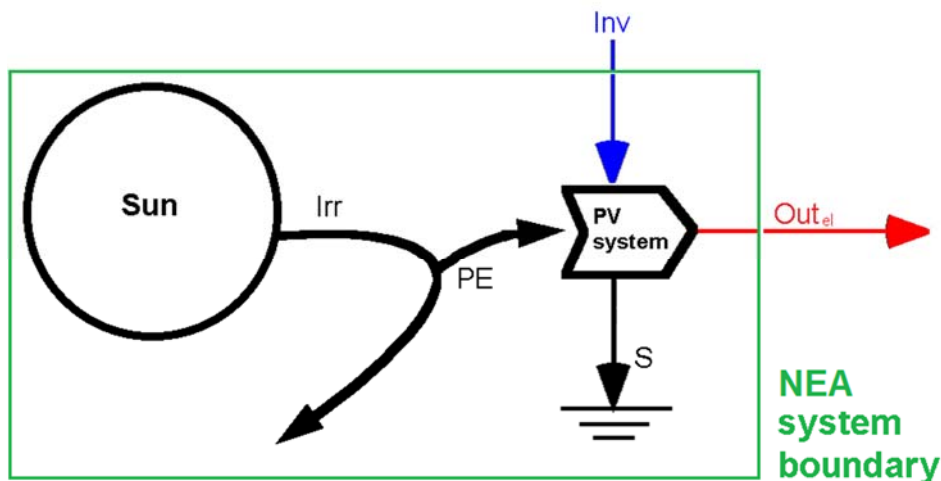

Figure 2 - Streamlined energy systems diagram of a PV power system.

The following basic definitions apply (units are reported per m^2 of PV system over the full system's lifetime):

- **Irr** = total solar irradiation over system's lifetime [MJ/m^2]
- **η_{PV}** = PV module energy harvesting efficiency [MJ/MJ]
- **PE** = primary energy directly harvested over system's lifetime
= **Irr** * **η_{PV}** [MJ/m^2]
- **Inv** = energy 'investment' to build, operate and dismantle (at end of life) the PV system, in terms of its primary energy demand [MJ/m^2]

- **PR** = performance ratio⁴ [MJ/MJ]
- **Out_{el}** = total electricity produced over system's lifetime = **PE * PR** [MJ/m²]
- **S** = energy dissipated to the environment (e.g. as heat) [MJ/m²]

Based on these definitions, and as discussed in **Section 2.2**, the EROI of PV electricity may be calculated according to either **Eq. 2** or **Eq. 3** below:

$$\text{Eq. 2) } \text{EROI}_{\text{el}} = \text{Out}_{\text{el}} / \text{Inv} \quad [\text{MJ/MJ}]$$

$$\text{Eq. 3) } \text{EROI}_{\text{PE-eq}} = \text{Out}_{\text{PE-eq}} / \text{Inv} = (\text{Out}_{\text{el}} / \eta_{\text{G}}) / \text{Inv} = \text{EROI}_{\text{el}} / \eta_{\text{G}} \quad [\text{MJ/MJ}]$$

where:

- η_{G} = life cycle energy efficiency of the electric grid (G) of the country or region where the analysed PV system is deployed, calculated as the ratio of the yearly electricity output of the entire grid to the total primary energy harvested from the environment for the operation of the grid in the same year, i.e.: $\eta_{\text{G}} = 1/\text{CED}_{\text{G}}$ [MJ/MJ].

Example EROI calculations for a typical recent rooftop-mounted mc-Si PV system (data from de Wild-Scholten [2013])

- **Irr** = 1,700 [kWh/(m²*yr)] * 3.6 [MJ/kWh] * 30 [yr] = 183,600 [MJ/m²]
- **η_{PV}** = 14.1 %
- **PE** = 25,888 [MJ/m²] = **Irr * η_{PV}**
- **Inv** = 2,444 [MJ/m²]
- **PR** = 0.75 [MJ/MJ]
- **Out_{el}** = 19,416 [MJ/m²] = **PE * PR**
- **EROI_{el}** = 7.9 [MJ/MJ] = **Out_{el} / Inv**
- **η_{G}** = 0.32 [MJ/MJ]
- **EROI_{PE-eq}** = 25 [MJ/MJ] = **EROI_{el} / η_{G}**

The adoption of **Eq. 3** allows the subsequent calculation of the net energy 'returned' to society in internally consistent units of primary energy:

$$\text{Eq. 4) } \text{Out}_{\text{NET}} = \text{Out}_{\text{PE-eq}} - \text{Inv} \quad [\text{MJ}]$$

⁴ The performance ratio (PR) describes the difference between the modules' (DC) rated performance (the product of irradiation and module efficiency) and the actual (AC) electricity generation (IEC 61724). It is here assumed to include age-related degradation.

At the same time, though, it is also noteworthy that calculating the EROI of PV according to **Eq. 3** results in a metric that is intrinsically comparative within PV electricity. In other words, the numerical value of $\mathbf{EROI}_{\text{PE-eq}}$ depends not only on the actual energy performance of the system under study, but also on that of the electric grid that it is assumed to (partially) replace. Any observed change in the $\mathbf{EROI}_{\text{PE-eq}}$ of a PV technology over time may therefore depend not (or at least not only) on a change in electricity output per unit of energy investment, but also on a change in the average life cycle efficiency of the electric grid.

Incidentally, as discussed elsewhere [Raugei, 2013a; Itten et al., 2014], a similar interpretational issue also applies to the Energy Pay-Back Time (**EPBT**) metric, whose definition also includes the same primary energy equivalency factor ($1/\eta_G$) [Frischknecht et al., 2016]. In fact, the two metrics are related as indicated in **Eq. 5**:

$$\mathbf{Eq. 5) \quad EROI}_{\text{PE-eq}} = T / \mathbf{EPBT}$$

where:

- **T** = PV system's lifetime [yr]
- **EPBT** = Energy Pay-Back Time = $\mathbf{Inv} / [(\mathbf{Out}_{\text{el}}/T) / \eta_G]$ [MJ*yr/MJ] \equiv [yr]

One key difference between $\mathbf{EROI}_{\text{PE-eq}}$ and **EPBT** is that $\mathbf{EROI}_{\text{PE-eq}}$ looks at the overall energy performance of the PV system as a whole over its entire lifetime, while **EPBT** is only concerned with how long it takes for the PV system to 'return' an amount of electricity that is deemed to be *equivalent* to the primary energy 'invested'.

Since in practice the largest part of the energy 'investment' for PV is required up front before the system starts to produce any electricity, while the energy 'return' is spread over the years of operating phase (*cf.* **Section 3.4.1**), in first approximation **EPBT** measures the point in time (**t**) after which the system is able to provide a positive net energy 'return' ($\mathbf{Out}_{\text{NET}}$), i.e.:

$$\mathbf{Eq. 6) \quad Out}_{\text{NET}}(\mathbf{t}) = \mathbf{Out}_{\text{PE-eq}}(\mathbf{t}) - \mathbf{Inv}(\mathbf{t}) > 0 \quad \text{when} \quad \mathbf{t} > \mathbf{EPBT}.$$

- In order to avoid potential confusion and maintain the transparency and traceability of the underlying calculations, it is considered mandatory to always specify the chosen approach to perform the EROI calculation (i.e., whether the energy output is expressed in terms of direct electricity – leading to $\mathbf{EROI}_{\text{el}}$ as per **Eq. 2** – or in terms of *equivalent* primary energy – leading to $\mathbf{EROI}_{\text{PE-eq}}$ as per **Eq. 3**).

So as to provide a frame of reference for comparison, **Figure 3** schematically illustrates a thermal electricity production system (whose feedstock may be a fossil fuel, a biofuel, or a nuclear fissile fuel).

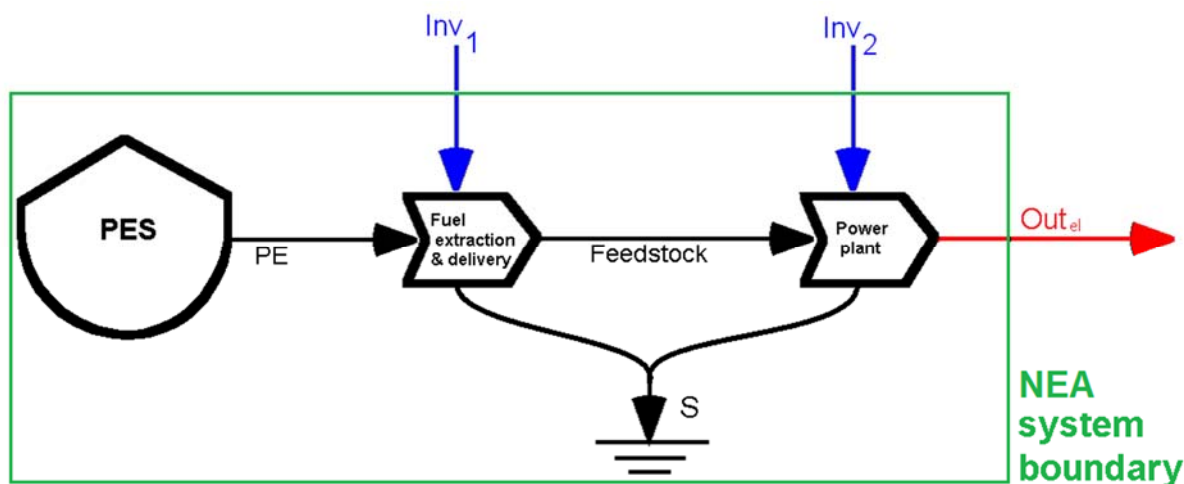

Figure 3 - Streamlined energy systems diagram of a thermal power system.

A similar set of energy flows as already illustrated in the case of **Figure 2** applies here too, with the notable difference of an additional ‘investment’ term (**Inv₁**) to account for the extraction, processing and delivery of the feedstock from the exploited PES:

- **PE** = primary energy directly harvested from the PES over system’s lifetime [MJ]
- **Inv₁** = energy ‘investment’ to extract, process, and deliver the feedstock, in terms of its primary energy demand [MJ]
- **Inv₂** = energy ‘investment’ to build, operate, and dismantle (at end of life) the power plant, in terms of its primary energy demand [MJ]
- **Out_{el}** = total electricity produced over system’s lifetime [MJ]
- **S** = energy dissipated to the environment (e.g., as heat, as fugitive emissions, etc.) [MJ]

The quantification of the energy investment for the extraction, processing and delivery of the feedstock (**Inv₁**) is often less straightforward than might be expected. This is because of the secondary energy flows which may be co-extracted and ‘lost’ (i.e., emitted) to the environment (e.g., the fugitive emissions of natural gas released from coal seams during mining), as well as any direct energy ‘losses’ along the supply chain, when the feedstock is processed and delivered. These ‘lost’ energy flows are, at least in principle, included in the life cycle inventories (LCI) that are often used by many analysts as their data sources of choice. However, they are not to be accounted for as part of **Inv₁**, because from the NEA perspective such ‘lost’ energy was never available in the form of usable energy carriers in the first place, and therefore it does not represent an energy ‘investment’ that is diverted from other possible societal uses [Arvesen and Hertwich, 2015]. Additionally, the quantification of **Inv₁** is often characterized by a lack of precision, especially when a number of different sources contribute to a country’s feedstock supply mix. Since (**Inv₁+Inv₂**) represents the entire denominator of the EROI ratio, and given that for many systems **Inv₁** is greater than **Inv₂**, this lack of precision often ends up entailing a correspondingly large uncertainty in the

quantification of the EROI of conventional thermal electricity production systems. (Since the energy directly extracted from the PES – i.e, **PE** – is generally much greater than both **Inv₁** and **Inv₂**, the same lack of precision is, instead, typically inconsequential for the purposes of calculating the CED and nr-CED metrics –cf. **Eq. 7** and **8** in **Section 3.2**).

3.2. Interpretation of EROI (*vis-à-vis* CED and nr-CED)

In Life Cycle Assessment (LCA) [ISO, 2006a], the ‘Cumulative Energy Demand’ (CED) metric describes the total primary energy that must be harvested from the environment in order to produce a given amount of usable energy carrier [Frischknecht et al., 2007; Frischknecht et al., 2015a].

Referring back to the general case illustrated in **Figure 1**, CED per unit output may be operationally defined as:

Eq. 7) $CED = (PE + Inv) / Out$ [MJ/MJ]

where both **PE** and **Inv** are expressed in terms of primary energy, while **Out** is expressed in direct energy units of the delivered energy carrier (e.g, electricity).

Additionally, LCA keeps separate track of all the renewable and non-renewable energy flows, leading to the possibility to compute the ‘non-renewable Cumulative Energy Demand’ (nr-CED) per unit output as well:

Eq. 8) $nr-CED = (PE_{nr} + Inv_{nr}) / Out$ [MJ/MJ]

where:

- **PE_{nr}** = non-renewable share of the primary energy directly harvested from the PES [MJ]
- **Inv_{nr}** = non-renewable share of the energy ‘investment’ for the chain of energy harvesting and transformation processes, in terms of its non-renewable primary energy demand [MJ]

Table 1 summarizes the main differences between the EROI metrics as discussed in **Sections 2.2** and **3.1** and the CED and nr-CED metrics as used in LCA, specifically in the case of electricity production.

Metric	EROI _{el}	EROI _{PE-eq}	CED	nr-CED
Formula	$\frac{Out_{el}}{Inv}$	$\frac{Out_{PE-eq}}{Inv} = \frac{(Out_{el}/\eta_G)}{Inv}$	$\frac{(PE+Inv)}{Out_{el}}$	$\frac{(PE_{nr}+Inv_{nr})}{Out_{el}}$
Units	[MJ / MJ]	[MJ / MJ]	[MJ / MJ]	[MJ / MJ]
Meaning of the numerator	Energy delivered ('returned') to society, <u>in units of electricity</u>	Energy delivered ('returned') to society, <u>in units of equivalent primary energy</u>	<u>Total primary energy</u> harvested from nature	<u>Non-renewable primary energy</u> harvested from nature
Meaning of the denominator	Sum of energy carriers diverted from other societal uses (excluding energy delivered to society), <u>in terms of their total primary energy demand</u>		Energy delivered ('returned') to society, <u>in units of electricity</u>	
Distinction between renewable and non-renewable energy?	No, not normally made		Yes, generally recommended	
Main purpose	Economical/effective use of available energy carriers		Efficient use of primary energy resources	Sustainable/efficient use of non-renewable primary energy resources
Temporal perspective	Short term		Long term	

Table 1 - Key differences between EROI_{el} / EROI_{PE-eq} and CED / nr-CED per unit output. (Acronyms, abbreviations and symbols: PE = primary energy; PE-eq = equivalent primary energy; Out = energy output; Inv = energy investment; el = electricity; η_G = life cycle energy efficiency of the electric grid (G); nr = non-renewable.)

First and foremost, it is essential to note that, unlike in CED (and nr-CED), the primary energy directly harvested from the PES (i.e., **PE**) plays no part in the definition of EROI. This has the direct consequence that while two systems may have the exact same EROI (**Out/Inv**), one may at the same time require a much larger amount of total primary energy in input (**PE+Inv**) per unit of delivered output (**Out**). In other words, one of the two systems having the same EROI may in fact be far less efficient than the other, when considering their respective total usage of primary energy. Thus, despite the sometimes liberal use of the word “efficiency” when referring to the information provided by the EROI ratio in the existing literature (e.g., [Hall et al., 1979]), it should in fact be self-explanatory that “the EROI metric is not to be interpreted as an overall measure of primary energy demand per unit of energy output, or a sort of ‘life cycle energy conversion efficiency’” [Raugei et al., 2012]. As discussed elsewhere [Raugei, 2013b; Raugei et al., 2015], this point is of crucial importance, and regrettably it has

sometimes been the object of misguided interpretation in the existing literature [Weißbach et al., 2013].

When all primary energy flows are duly taken into account, CED and nr-CED are the appropriate metrics to inform on how *efficient* a system is, on the full life cycle scale, in *converting* the (respectively, total or non-renewable) primary energy harvested into a usable energy carrier (i.e. how much – or how little – energy, from the exploited resource(s) *plus* from the additional energy investment, is required per unit of delivered energy carrier).

Instead, what EROI provides is a valuable indication of how *effective* a system is in *exploiting* a primary energy resource (i.e., how much – or how little – *additional* energy investment is required per unit of delivered energy carrier).

It is also important to note that EROI generally indicates effectiveness without differentiating between renewable and non-renewable energy inputs (though in isolated exceptions such a distinction has been proposed in the NEA literature [Dale, 2007; Murphy et al., 2011]). As a consequence, even when two systems exert the same leverage of energy investments (i.e., are characterised by the same EROI), one may still lead to a faster depletion of non-renewable primary energy resources than the other (if its EROI is achieved mainly by exploiting non-renewable primary energy stocks rather than by harvesting renewable primary energy flows).

These differences are consequential in terms of the relevance of the two families of metrics on different time scales and for different societal purposes.

The EROI metric is devised to inform how much energy can be harvested and transformed into a usable energy carrier by a given technology (or mix of technologies), per unit of energy already available at one's disposal, with the underlying goal of achieving the most effective use of the available energy carriers *in the short term*. The rationale for this lies in the assumption that if major, large-scale changes were made to the energy sector as a whole, which quickly resulted in drastically reduced energy output per unit of energy investment (i.e., lower EROI), then, given the current societal energy consumption patterns, there would be little available energy left to devote to other societal uses (notably including the development and deployment of alternative, and potentially more efficient, energy production systems).

On the other hand, the perspective offered by the CED and nr-CED metrics (when renewable and non-renewable energy use is differentiated, as recommended here) is intrinsically long-term, and specifically, the underlying goal of calculating the nr-CED of a range of energy technologies is to identify those which minimize the overall squandering of non-renewable primary energy resources per unit of usable energy delivered to society.

EROI and CED / nr-CED, the latter based on LCA, are thus suited for different scopes. They both have their strengths and either of them is useful in a particular context and for answering specific questions.

A useful analogy to further illustrate the differences and complementarity of the NEA and LCA viewpoints is that of a system composed of a predator and its prey. Such a predator-prey interaction results in a net energy ‘return’ only if the energy obtained by eating the prey (i.e., the energy ‘return’) is larger than the energy expended by the predator to hunt it and kill it (the energy ‘investment’). However, there is one important caveat in this seemingly simple state of matters. If the predator animal is very effective in hunting (i.e., if the energy invested in hunting is much lower than the energy ‘returned’ by the prey), but the prey animals become extinct within one season (i.e., if they are not ‘renewable’ within the time frame of interest for the predator), then such hunting effectiveness ends up being of little help in ensuring the long term survival of the predator. On the other hand, a different predator species that hunts less effectively (i.e., which expends more energy per unit of energy ‘returned’ by its prey) and which does not grow as quickly in population, may allow the population of its prey animals to also be more resilient and avoid collapse (i.e., such prey animals may, for all intents and purposes, be a ‘renewable’ resource for their predator). Thus, while *in the short term* the more effective predator appears to win out, *in the long term* the less effective hunting strategy of the second predator is more sustainable.

Similarly, if a society strives to obtain the high net energy ‘return’ that it needs to flourish in the short term from *non-renewable* (instead of *renewable*) energy sources, then it is arguably rather short-sighted. Ultimately, a fundamental choice may need to be made between seeking “a short life in affluence” (as one based on high-EROI systems feeding on non-renewable energy sources would be) or “a long life in sufficiency” (i.e., one based on energy supply systems with a low nr-CED). Interestingly, this highly decisive and normative choice was already lucidly described in Clausius [1885] and Jevons [1965].

3.3 Photovoltaics-specific aspects

Regarding life expectancy, irradiation, performance ratio, and degradation specific to PV, the following general recommended figures may be used in most common cases:

- Life expectancy = 30 years (PV modules, supporting structure, transformers, cabling, large inverters); 15 years (small inverters)
- Irradiation = use average actual orientation, shading and irradiation (country-specific estimates for the latter are available in the literature)
- Performance ratio = 0.75 (rooftop-mounted PV); 0.80 (ground-mounted PV)
- Degradation = assume linear yearly degradation rates of 0.7% (default) and 0.5% (sensitivity analysis)

For further details, the reader is referred to the companion document “Methodology Guidelines on Life Cycle Assessment of Photovoltaic Electricity” [Frischknecht et al., 2016], Sections 3.1.1 – 3.1.4. The same methodological guidelines apply here too.

3.4 Modelling aspects

3.4.1 'Integrated' vs. 'dynamic' modelling

Most conventional NEAs adopt an integrated modelling approach over the full life cycle of the system, which considers all the energy inputs and outputs to/from the system at once. Accordingly, an overall EROI value is computed which applies to the full life cycle of the system, and the calculations are performed in the same way, irrespective of when, along the time line of the life cycle of the system, the individual contributions to the total energy 'investment', and to the total energy 'return' actually take place.

A more realistic (albeit still streamlined) depiction of the dynamic reality of a generalised energy system is illustrated in **Figure 4** (adapted from Herendeen [2004]), in which the following terminology is used:

- **Inv_c** = up-front energy 'investment' for system *construction* (over time **t_c**)
- **Inv_{op}** = energy 'investment' for system *operation*, maintenance and treatment of waste generated during use phase (over time **t_l**)
- **Inv_d** = energy 'investment' for system *decommissioning* at end of life (over time **t_d**)
- **Out** = energy 'return' during use phase (over time **t_l**)

In terms of the full 'life cycle' models previously illustrated in **Figures 2** and **3**, we have that, respectively:

- **Inv_c + Inv_{op} + Inv_d = Inv** (Figure 2)

and

- **Inv_c + Inv_{op} + Inv_d = Inv₁ + Inv₂** (Figure 3)

where, in particular, **Inv₁** is part of **Inv_{op}**.

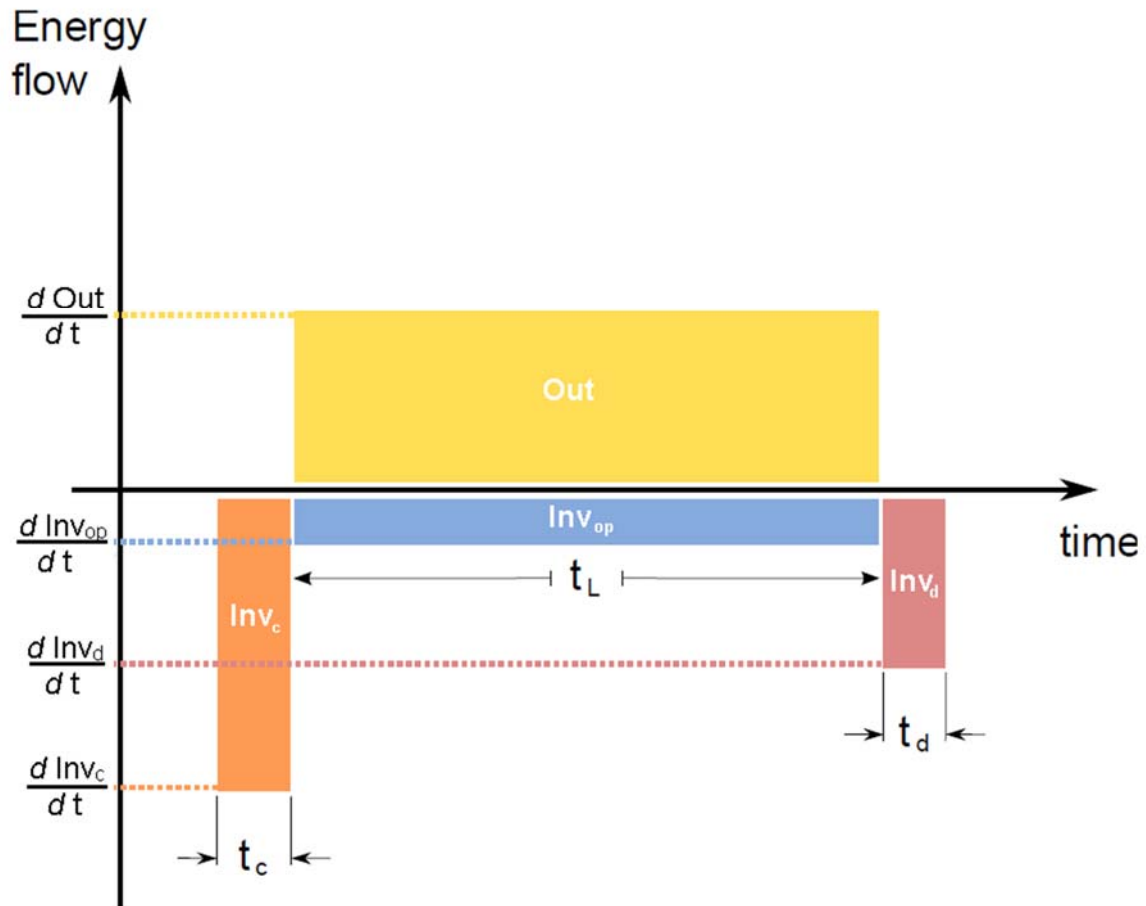

Figure 4 - Schematic depiction of the actual spread over time of the energy ‘investments’ ($Inv_c + Inv_{op} + Inv_d$) and energy ‘return’ (**Out**) of a generalized energy system (adapted from Herendeen [2004]). The individual areas are drawn for illustrative purposes only, and are not intended to be representative of any specific energy technology.

While the ‘integrated’ modelling approach provides a fairly accurate depiction of the real state of matters for those energy systems (like conventional thermal electricity production systems) for which the largest share of the energy ‘investment’ (that for the extraction, processing, and delivery of the feedstock) and the production of the energy output (also referred to as energy ‘return’) are spread evenly alongside one another, the situation is radically different for those systems (like PVs, and other renewables) for which almost all the energy ‘investment’ is clustered at the beginning of the life cycle (Inv_c for system manufacturing), while the energy output is still spread over the much longer use phase.

One first consequence of this initial clustering of the energy investment for PV is that, if calculated with a dynamic modelling approach along the timeline of the life cycle of the system, the EROI as a function of time (**EROI(t)**) would initially be lower than the ‘integrated’ value calculated over the full life cycle, and it would then become higher and higher as the up-front energy investment is first gradually ‘repaid’, and then overcompensated by the electricity produced by the system.

Such dynamic issues would become even more relevant in prospective and consequential NEAs of potential large-scale deployment of PVs (and other renewable energy technologies), where the scope of the analysis is extended to the scale of the PV industry, rather than limited to that of a single system (*cf.* **Section 3.4.4**).

Since at the industry scale there is no readily identifiable ‘system lifetime’, the conventional definitions of $EROI_{el}$ and $EROI_{PE-eq}$ as given respectively by **Eq. 2** and **Eq. 3** no longer apply, and in fact the use of the very term “EROI” at this larger scale becomes potentially confusing and misleading, and it is therefore here discouraged.

In principle, a flow-based metric of Net Power Output could instead be defined, which would be low or even negative during periods of heavy investment, corresponding to, for example, ramp-up phases of large-scale deployment of new PVs, and then become higher when, in a more ‘mature’ market, a large number of PV systems are on-line and actively produce electricity [Carbajales-Dale et al., 2014b].

3.4.2 Goal definition

In the past, NEAs have been carried out with a range of different goals, which may be classified into three broad categories [Carbajales-Dale et al., 2015]:

1. Short-term analysis of a specific energy system (e.g., PV electricity production);
2. Comparative assessment of a range of energy systems (e.g., PV vs. other electricity production technologies);
3. Calculation of the (minimum) EROI that a technology (or mix of technologies) must have in order to be able to (either single-handedly or when combined) adequately support a given industrial society in the short term.

Clearly, each of the goals enumerated above requires setting appropriate (and different) system boundaries (*cf.* **Section 3.4.4**).

Goal category (1) is the most straightforward of the three, and the one to which the guidelines of the present document most directly and comprehensively refer. It may be used to assess the development of the EROI of a given technology (e.g., PV) in the course of time. It is not suited for comparisons across technologies.

The goal category (2) is limited to a *short-term* assessment of the most effective / economical⁵ use of the available energy carriers. This is because the EROI metric as defined in NEA does not account for the amount of primary energy resource that is directly exploited (**PE**), and it does not generally distinguish between renewable and non-renewable energy resources. Therefore, a comparison of EROI results does not help in identifying the technology that makes the most efficient overall use of the available stocks of energy resources, and which

⁵ “Economical” is not to be intended here in the monetary term, but in the more general sense of “giving good value or return in relation to the effort expended”.

may therefore be the preferable option in the long term. For the latter, we recommend using CED and nr-CED as calculated in process-based LCA.

Finally, addressing goal category (3) entails a further widening of the system boundary to also include a number of energy ‘investments’ that are indirectly required to perform the intended function at the societal level (i.e., provide a sufficient⁶ short-term net energy ‘return’ to society – to be assessed in the specific context of the country / region of interest, and ensuring the consistent use of suitable primary energy units in both numerator and denominator – cf. **Sections 2.2** and **3.1**).

Specifically, the inclusion of energy storage devices within the system boundary is only justified under goal category (3), since the majority of electricity production technologies (including renewables like PV and wind electricity, *as well as* baseload technologies such as coal-fired and nuclear electricity) are, in fact, not able to single-handedly follow the pattern of electricity demand, and, if deployed on their own, they would all require *some* storage capacity (and/or complementary generation assets) in order to do so. That being the case, it is in fact considered preferable and more meaningful to only address the issue of energy storage at the level of the country’s or region’s grid mix, rather than at the level of any individual electricity production technology [Carbajales-Dale et al., 2015].

- It is therefore considered mandatory to explicitly state the intended goal of the study prior to presenting the results of any NEA of PVs.

3.4.3 Functional unit

We recommend the following functional unit for the NEA of PV electricity:

- 1 MJ (or alternatively 1 kWh) of AC electricity delivered to the grid (suitable for comparing PV technologies, module technologies, and electricity generating technologies in general).

Aspects of dispatchability or intermittency of AC electricity produced with different technologies shall not be addressed on technology level but on the level of grid mixes provided by utilities (cf. **Section 3.4.2**).

For further details, the reader is referred to the companion document “Methodology Guidelines on Life Cycle Assessment of Photovoltaic Electricity” [Frischknecht et al., 2015b], Section 3.2.2. The same methodological guidelines apply here too.

3.4.4 System boundary

In spite of the deceptively simple definition of EROI as an energy ratio (cf. **Section 2.2**), its actual calculation is intimately dependent on the choice of system boundary, which affects

⁶ It is hereby noted that the quantitative determination of the minimum EROI that results in a “sufficient” net energy ‘return’ to support an industrial society is still the object of speculation [Hall et al., 2009; Lambert et al., 2014].

what is included in both the numerator (the energy delivered – also referred to as ‘returned’ – by the system) and the denominator (the energy ‘invested’) [Zhang et al., 2013].

Effects on the numerator of the EROI ratio

The way in which the boundary affects the numerator is relatively straightforward: it defines the stage of the energy supply chain at which an energy carrier is identified as the system’s output (e.g., whether a NEA refers to a fossil fuel at the well or mine head, to a refined secondary fuel such as, for instance, heavy fuel oil or kerosene, to electricity at the power plant gate, or to electricity delivered at the point of use) [Hall et al., 2014].

- In comparative NEAs (*cf.* goal category (2) as defined in **Section 3.4.2**), it is considered here mandatory to always explicitly state the energy carrier to which each calculated EROI applies (e.g., electricity at the power plant gate), and to refrain at all times from explicitly or implicitly (e.g., by presenting them alongside one another in the same table or figure) comparing EROI results that apply to different energy carriers (e.g., liquid fuels and electricity). It should additionally be highlighted that such comparisons have a short-term perspective (showing the economical/effective use of available energy carriers) and do not allow identification of the long-term optimal energy technologies (showing the sustainable/efficient use of primary energy resources) because the main primary energy resource being harvested is excluded from the calculation of EROI, and no distinction is made between renewable and non-renewable energy resources.

The quantification of the numerator is also dependent on the choice of allocation procedures when dealing with systems involving multiple products. This equally applies to both NEA and LCA, and it is hereby advised to adhere to the current ISO recommendations on allocation [ISO, 2006b].

Effects on the denominator of the EROI ratio

The dependence of the denominator on the system boundary is more complex, and requires a deeper discussion, as follows.

Level-1 (narrow boundary)

In the narrowest possible definition of the EROI ratio, only those energy ‘investments’ that are directly input as energy carriers on the scale of the energy transformation process(es) being considered would take part in the calculation of the denominator (in units of energy carrier, i.e., thermal energy or electrical energy). A reduced-scope analysis of this type would essentially correspond to only accounting for those direct energy ‘investments’ that would be characterized as ‘foreground’ inputs in LCA⁷. While unquestionably the easiest option, and

⁷ The LCA definition of ‘foreground’ refers to those processes “...that are under direct control of the producer of the good or operator of the service, or user of the good or where he has decisive influence...This covers firstly all in-house processes of the producer or service operator of the analyzed system. Secondly...also all processes and suppliers of purchased made-to-order goods and services, i.e., as far as the producer of service operator of the analyzed system can influence them by choice or specification” [JRC, 2010, p.97].

the one often capable of producing the most precise results, adopting such a narrow system boundary would arguably be misguided since: (a) as already explained in **Section 2.2**, it would entail the inconsistent sum of a range of ‘investments’ which are supplied as different and not directly comparable energy carriers (e.g., liquid fuels and electricity); and (b) it would often result in the exclusion of a number of potentially significant energy ‘investments’ which take place in the system’s ‘background’. Adopting this narrowest approach is therefore not recommended.

Level-2 (intermediate boundary)

A wider – and arguably more methodologically correct – definition of system boundary entails including in the analysis not only the direct energy investments (those taking place at the foreground level), but also all the indirect (background) ‘investments’ which occur along the supply chains of the foreground inputs (i.e., also including the ‘embodied primary energy’ of the direct material and energy inputs), and expressing all investments in units of their primary energy demand (*cf.* **Section 2.2**). This is the system boundary that best matches the one typically adopted in most process- and product-oriented attributional LCAs, and it is the largest system boundary that can still be addressed in terms of purely physical units. It is also the boundary that ensures the maximum internal methodological consistency in comparative NEAs of different energy systems (*cf.* goal category (2) as defined in **Section 3.4.2**), as well as external methodological consistency with the largest number of published and peer-reviewed LCAs and NEAs to date. From a practical standpoint, in order to ensure that such consistency is indeed attained, the use of a coherent source of data (e.g., the same vetted and trustworthy LCI database) and calculation method (i.e., the CED method as described in [Frischknecht et al., 2007; Frischknecht et al., 2015a] and implemented in selected LCA software packages) is recommended.

- The adoption of this intermediate (wider, but still based on purely physical units) system boundary that includes direct and indirect energy investments is therefore recommended here for the NEA of PV electricity (*cf.* goal category (1) as defined in **Section 3.4.2**), as well as for all NEAs aimed at comparing alternative electricity production technologies (*cf.* goal category (2) as defined in **Section 3.4.2**).

Level-3 (wide boundary)

Setting an even wider system boundary is possible in principle, and in fact, attempts at doing so are documented in the literature [Prieto and Hall, 2013; Lambert et al., 2014]. In general terms, the system boundary may be further expanded to also include those non-energy resources that are related to the life cycle (manufacturing, operation, and end-of-life) of the

By contrast, background data “...comprises those processes that are operated as part of the system, but that are not under direct control or decisive influence of the producer of the good (or operator of the service, or user of the good). The background processes and systems are hence outside the direct influence or choice of the producer or service operator of the analyzed system” [JRC, 2010, p. 98].

analysed system, but which are only normally accounted for as monetary inputs (such as insurance, etc.).

Such a boundary expansion may be considered appropriate when the intended goal of the NEA is to investigate the minimum EROI that is required at the societal level (*cf.* goal category (3) as defined in **Section 3.4.2**). However, opting for such further expanded system boundary inescapably calls for hybrid physical-and-economic approaches, ranging from the application of crude ‘energy-to-money’ ratios [Prieto and Hall, 2013] to the more elaborate use of economic Input-Output tables as done in hybrid Input-Output LCA (IO-LCA)⁸ [Joshi, 2000]. These approaches are not followed in this subtask, as it is believed that more confidence in employing them is needed before their application may be recommended [Frischknecht et al., 2016].

A further problem with such expanded system boundary is that the system’s behaviour at the societal level is always intrinsically dynamic, and there often is no readily identifiable ‘system lifetime’ (*cf.* **Section 3.4.1**). For instance, if monetary investments made at the level of a country’s entire PV industry are converted into energy units and included in the calculation of the EROI denominator (as done for instance in [Prieto and Hall, 2013]), then the fundamental premise that the system is being analysed using an ‘integrated’ approach over its full life cycle no longer holds, especially during periods of heavy industry-level investment. If the temporal boundary of the analysis is then artificially constrained (e.g., to one year), and the calculations are performed as though they still referred to an ‘integrated cycle’ of the same duration, then an implicit mismatch is produced between the intended goal of the analysis and the adopted system boundary, and the results lose validity [Carbajales-Dale et al., 2015].

- In light of all the considerations above, it is considered mandatory to explicitly state the adopted system boundary (and to discuss the inherent methodological limitations) prior to presenting the results of any NEA of PVs.

3.4.5 Modelling allocation and recycling

Consistent allocation rules are demanded for all multifunction processes⁹, use of recycled material inputs, recycling of materials at end of life, and use of waste heat (e.g., heat recovery in municipal waste incinerators). We recommend following international standards regarding allocation, which is addressed in the ISO standard 14044, Clause 4.3.4 "Allocation" [ISO, 2006b].

⁸ It is noted, though, that human labour is excluded from classical Input-Output analysis [Leontief, 1985].

⁹ Those processes simultaneously producing several different products, such as off-grade silicon supply as a by-product of electronic-grade silicon.

3.5 Reporting and communication

Reporting of items 1 to 16 below is considered mandatory. The list of items is separated in key parameters required in both the captions of figures and tables showing the results of the NEA and in the NEA report (items 1 to 6), and further important aspects which should be documented elsewhere in the NEA report.

Key parameters that should be documented in captions of figures and tables:

1. PV technology (single and multi-crystalline silicon, CdTe, CIS, amorphous silicon, micromorphous silicon);
2. Type of system (e.g., roof-top, ground mount, fixed tilt or tracker);
3. Module-rated efficiency and degradation rate (if not included in performance ratio);
4. Lifetime for both PV modules and balance of system (BOS);
5. Location of installation;
6. Annual irradiation level, and expected annual electricity production with the given orientation and inclination *or* system's performance ratio (PR).

Other important aspects that should be documented in the NEA report:

7. Place/country/region of electricity production modelled;
8. Time-frame of data used in the analysis;
9. Whether $EROI_{el}$ or $EROI_{PE-eq}$ is calculated, and if the latter, the assumed electricity mix or technology/-ies and thus resulting grid mix's or technology's/-ies' efficiency (*cf.* **Section 3.1**);
10. Goal of the study (*cf.* **Section 3.4.2**);
11. System boundary (*cf.* **Section 3.4.4**);
12. Approach used if not process-based (e.g. environmentally extended input-output tables, hybrid analysis);
13. LCA database(s) (e.g., Ecoinvent, GaBi, ELCD, etc.) and version used (if applicable);
14. LCA software tool (e.g., SimaPro, GaBi, OpenLCA, etc.) and version used (if applicable);
15. Primary energy factors applied and approach used;
16. Any major assumptions made on the production of input materials.

Acknowledgements

The authors gratefully acknowledge the many valuable comments and suggestions made by two independent experts who acted as external reviewers of a draft version of these guidelines.

References

- Arvesen A., Hertwich E.G., 2015. More caution is needed when using life cycle assessment to determine energy return on investment (EROI). *Energy Policy* 76:1-6.
- Bhandari K.P., Collier J.M., Ellingson R.J., Apul D.S., 2015. Energy Payback Time (EPBT) and energy return on energy invested (EROI) of solar photovoltaic systems: A systematic review and meta-analysis. *Renewable and Sustainable Energy Reviews* 47:133-141.
- Berndt E.R., 1982. *From Technocracy to Net Energy Analysis: Engineers, Economists and Recurring Energy Theories of Value*. Studies in Energy and the American Economy Discussion Paper No. 11, MIT-EL 81-065WP. Retrieved from: <http://dspace.mit.edu/bitstream/handle/1721.1/2023/SWP-1353-09057784.pdf>.
- Brandt A.R., 2011. Oil depletion and the energy efficiency of oil production: The case of California. *Sustainability* 3(10): 1833-1854.
- Brandt A.R., Carbajales-Dale M., Barnhart C.J., 2013. Calculating systems-scale energy efficiency and net energy returns: A bottom-up matrix-based approach. *Energy* 62:235–247.
- Carbajales-Dale M., Barnhart C.J., Brandt A.R., Benson S.M., 2014a. A better currency for investing in a sustainable future. *Nature Climate Change* 4:524-527.
- Carbajales-Dale M., Barnhart C.J., Benson S.M., 2014b. Can we afford storage? A dynamic net energy analysis of renewable electricity generation supported by energy storage. *Energy & Environmental Science* 7:1538-1544.
- Carbajales-Dale M., Raugei M., Barnhart C.J., Fthenakis V., 2015. Energy return on investment (EROI) of solar PV: an attempt at reconciliation. *Proceedings of the IEEE*, DOI: 10.1109/JPROC.2015.2438471.
- Chambers, R.S., Herendeen, R.A., Joyce, J.J., Penner, P.S., 1979. Gasohol: Does it or doesn't it produce positive net energy? *Science* 206:789–795.
- Clausius R., 1885. *Über die Energievorräthe der Natur und ihre Verwerthung zum Nutzen der Menschheit* (On the Energy Supplies of Nature and the Utilization of them for the Benefit of Mankind). Bonn: Verlag von Max Cohen & Sohn.
- Cleveland C., 1992. Energy quality and energy surplus in the extraction of fossil fuels in the U.S. *Ecological Economics* 6:139–162.
- Cleveland C., 2008. *Ten fundamental principles of net energy*. Retrieved from: <http://www.eoearth.org/view/article/51cbef057896bb431f69be35>.
- Cleveland C., 2013. *Net energy analysis*. Retrieved from: <http://www.eoearth.org/view/article/154821/>.

- Cleveland C.J., Costanza R., Hall C.A.S., Kaufmann R., 1984. Energy and the U.S. Economy: a biophysical perspective. *Science* 225:890–897.
- Dale B.E., 2007. Thinking clearly about biofuels: ending the irrelevant ‘net energy’ debate and developing better performance metrics for alternative fuels. *Biofuels, Bioproducts & Biorefining* 1:14-17.
- de Wild-Scholten M., 2013. Energy payback time and carbon footprint of commercial photovoltaic systems. *Solar Energy Materials & Solar Cells* 119, 296-305.
- Frischknecht R., Jungbluth N., Althaus H.-J., Bauer C., Doka G., Dones R., Hellweg S., Hischier R., Humbert S., Margni M., Nemecek T., 2007. Implementation of Life Cycle Impact Assessment Methods. ecoinvent report No. 3, v2.0. Swiss Centre for Life Cycle Inventories, Dübendorf, CH. Retrieved from: www.ecoinvent.org.
- Frischknecht R., Wyss F., Büsser Knöpfel S., Lützkendorf T., Balouktsi M., 2015a. Cumulative energy demand in LCA: the energy harvested approach. *The International Journal of Life Cycle Assessment*, DOI: 10.1007/s11367-015-0897-4.
- Frischknecht R., Heath G., Raugei M., Sinha P., de Wild-Scholten M., Fthenakis V., Kim H. C., Alsema E. and Held M. 2016. Methodology Guidelines on Life Cycle Assessment of Photovoltaic Electricity, 3rd edition. International Energy Agency (IEA), Paris. Report IEA-PVPS T12-08:2016, ISBN 978-3-906042-39-8.
- Geddes P., 1884. *An analysis of the principles of economics*. In: Proceedings of the Royal Society of Edinburgh, XII, pp 943–980.
- Hall C.A.S., Lavine M., Sloane, J., 1979. Efficiency of energy delivery systems: I. An economic and energy analysis. *Environmental Management* 3:493-504.
- Hall C.A.S., Balogh S., Murphy D.J.R., 2009. What is the Minimum EROI that a Sustainable Society Must Have? *Energies* 2:25-47.
- Hall C.A.S., Lambert J.G., Balogh S.B., 2014. EROI of different fuels and the implications for society. *Energy Policy* 64:141-152.
- Hatfield M., 1974. *Net Energy*. The U.S. Congressional Record, Vol. 120, Part 5, March 11, 1974, pp. 6053-6076.
- Henshaw P.F., King C., Zarnikau J., 2011. System Energy Assessment (SEA), Defining a Standard Measure of EROI for Energy Businesses as Whole Systems. *Sustainability* 3:1908-1943.
- Herendeen R., 1988. *Net energy considerations*. In: West R., Kreith F. (Eds.), *Economic Analysis of Solar Thermal Energy Systems*. MIT Press, pp. 255–273.

- Herendeen R., 2004. *Net energy analysis: concepts and methods*. In: Cleveland C.J. (Ed.), *Encyclopedia of Energy*. Elsevier, pp. 283–289.
- International Organization for Standardization (ISO), 2006a. 14040 - *Environmental Management. Life Cycle Assessment. Principles and Framework*.
- International Organization for Standardization (ISO), 2006b. 14044 - *Environmental Management. Life Cycle Assessment. Requirements and Guidelines*.
- Itten R., Wyss F., Frischknecht R., Blanc I., Heath G., Raugei M., Sinha P., Wade A., 2014. *Life cycle assessment of future photovoltaic electricity production from residential-scale systems operated in Europe*. IEA-PVPS Task 12, Report T12-05:2014.
- Jevons W. S., 1965. *The Coal Question. An Inquiry Concerning the Progress of the Nation and the Probable Exhaustion of our Coal-Mines*, 3rd revised edition, New York, USA.
- Joint Research Centre (JRC) - Institute of Environment and Sustainability, European Commission, 2010. *ILCD Handbook: General guide for Life Cycle Assessment: detailed guidance*. Retrieved from: <http://ict.jrc.ec.europa.eu/pdf-directory/ILCD-Handbook-General-guide-for-LCA-DETAIL-online-12March2010.pdf>.
- Joshi S., 2000. Product Environmental Life-Cycle Assessment Using Input-Output Techniques. *Journal of Industrial Ecology* 3(2&3):95-120.
- King C., Hall C.A.S., 2011. Relating Financial and Energy Return on Investment. *Sustainability* 3:1810-1832.
- Lambert J.G., Hall C.A.S., Balogh S., Gupta A., Arnold M., 2014. Energy, EROI and quality of life. *Energy Policy* 64:153-167.
- Leach G., 1975. Net energy-is it any use? *Energy Policy* 3:332–344.
- Leontief W., 1985. *Input-Output Analysis*. In: Bever M.B. (Ed.), *Encyclopedia of Materials Science and Engineering*, Volume 3, F-I, Pergamon Press, Oxford and other locations, p. 2339-2349.
- Lloyd, B., Forest, A.S., 2010. The transition to renewables: Can PV provide an answer to the peak oil and climate change challenges? *Energy Policy* 38 (11):7378–7392.
- Mulder K., Hagens N.J., 2008. Energy Return on Investment: Toward a Consistent Framework. *AMBIO: A Journal of the Human Environment* 37(2):74-79.
- Murphy D.J., Hall C.A.S., 2010. Year in review—EROI or energy return on (energy) invested. *Annals of the New York Academy of Sciences* 1185:102–118
- Murphy D.J., Hall C.A.S., 2011. Energy return on investment, peak oil, and the end of economic growth. *Annals of the New York Academy of Sciences* 1219:52-72.

- Murphy D.J., Hall C.A.S., Dale M., Cleveland C., 2011. Order from Chaos: A Preliminary Protocol for Determining the EROI of Fuels. *Sustainability* 3: 1888-1907.
- Odum H.T., 1983. *Systems Ecology: An Introduction*. John Wiley and Sons, Hoboken, NJ, USA.
- Pickard W.F., 2014. Energy return on energy invested (EROI): a quintessential but possibly inadequate metric for sustainability in a solar-powered world? *Proceedings of the IEEE* 102(8):1118–1122.
- Prieto P., Hall C.A.S., 2013. *Spain's Photovoltaic Revolution. The Energy Return on Investment*. Springer, ISBN 978-1-4419-9437-0.
- Raugei M., 2013a. Energy Pay-Back Time: methodological caveats and future scenarios. *Progress in Photovoltaics: Research and Applications* 21:797-801.
- Raugei M., 2013b. Comments on "Energy intensities, EROIs (energy returned on invested), and energy payback times of electricity generating power plants" - making clear of quite some confusion. *Energy* 59:781-782.
- Raugei M., Carbajales-Dale M., Barnhart C.J., Fthenakis V., 2015. Rebuttal: "Comments on 'Energy intensities, EROIs (energy returned on invested), and energy payback times of electricity generating power plants' - Making clear of quite some confusion". *Energy* 82(15):1088-1091.
- Raugei M., Fullana-i-Palmer P., Fthenakis V., 2012. The Energy Return on Energy Investment (EROI) of Photovoltaics: Methodology and Comparisons with Fossil Fuel Life Cycles. *Energy Policy* 45:576-582.
- Sacher E., 1881. *Grundzüge einer Mechanik der Gesellschaft, Theil I* (Outlines of a Mechanics of Society, Part I). Jena: Gustav Fischer.
- Slessor M. (Ed.), 1974. *Energy Analysis Workshop on Methodology and Conventions*, pp. 89. IFIAS, Stockholm, Sweden.
- Weißbach D., Ruprecht G., Huke A., Czerski K., Gottlieb S., Hussein A., 2013. Energy intensities, EROIs (energy returned on invested), and energy payback times of electricity generating power plants. *Energy* 52:210-221.
- Zhang Y., Colosi L.M., 2013. Practical ambiguities during calculation of energy ratios and their impacts on life cycle assessment calculations. *Energy Policy* 57: 630-633.



ISBN 978-3-906042-38-1



9 783906 042381 >